

MI heating cable structure is made of electric heating alloy wire (heating body), inorganic mineral insulator and sheath metal sleeve after repeated stretching to form a solid body with high density. It can meet the needs of high temperature conditions and high heating power (up to 250W/m), and the highest temperature can reach 600°C; the conductor resistance value ranges from 0.002Q/m to 36Q/m, and it has excellent mechanical strength and corrosion resistance. Mainly used in nuclear industry, construction industry, metal manufacturing industry, tanks, container heating, high-temperature industrial pipeline heating, process media anti-condensation and viscosity reduction, various industrial electric heaters, etc., and has been verified by more than four international applications. ten years.

MI heating cable name

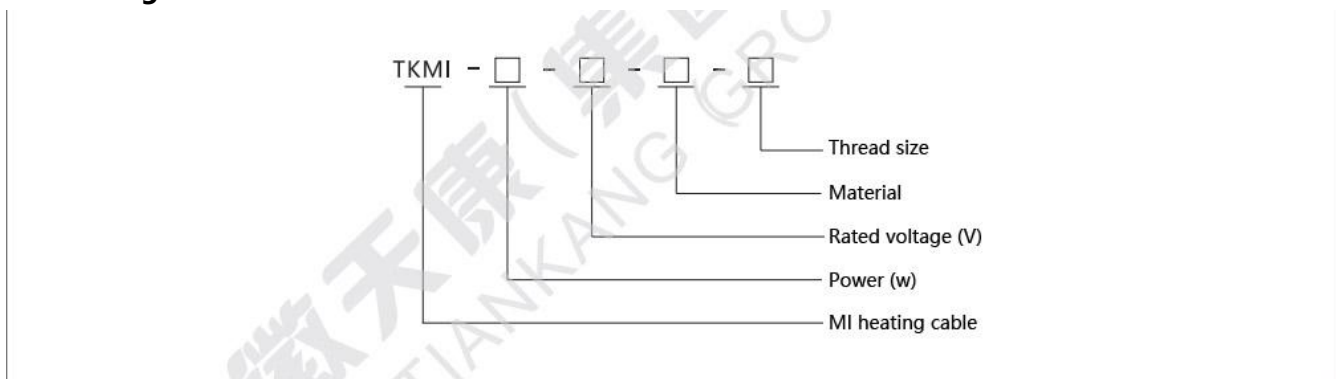

MI heating cable structure

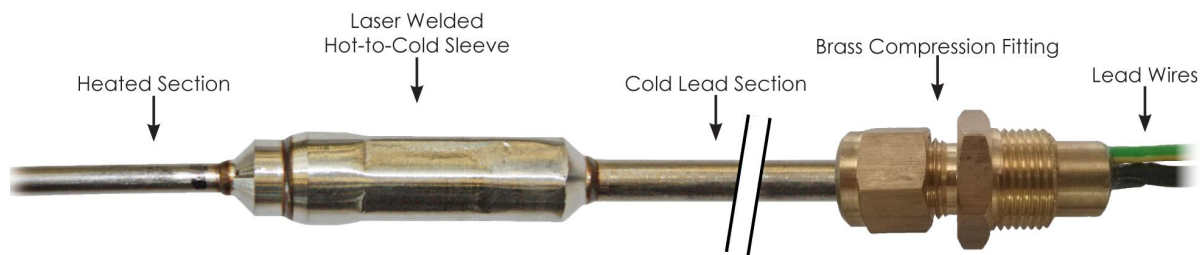

MI heating cable Characteristic parameter

Technical parameter		Nickel chromium stainless steel sleeve structure	825Alloy sleeve structure
Heating power (W/m)		50-250	50-250
Maximum surface temperature (°C)		650	800
Maximum operating temperature (°C)		450	550
external diameter (mm)	Single core	Ø3.5-6.5	Ø3.5-6.5
	Double core	Ø5.5-11	Ø5.5-11
Material (mm)	Conductive core wire	Nickel chromium alloy	Nickel chromium alloy
	Insulating material	Magnesia powder	Magnesia powder
	Metal sheath	stainless steel	825alloy

ADVANTAGE

Heat Tracing Cable

Mineral Insulated Heating Cables



Insulated magnesium oxide (MgO₂)
The MgO₂ is made according to industrial standard, which have better quality of insulation.

Industrial Standard
The insulated (MgO₂) is manufactured by Intaye and can meet the industrial standard.

825 Alloy Protective Sheath
It can withstand the temperature of 1200°C so it can be used in the extremely high temperature and high-power generation.

Single Core

Dual Core



- ① Protective Sheath (Stainless Steel, Copper) ② Mineral Insulated layer(MgO₂, Al₂O₃)
③ Conductor, heating material, Ni-Cr(Constantan,Copper)

MI heating cable Technical index

- Length: $\pm 2\%$.
- Resistance value tolerance: $\pm 10\%$.
- Withstand voltage performance: heating cable withstand voltage, 1500VAC/1min.
- Heating element withstand voltage: 1200VAC/1min
- Insulation resistance: finished product test -100MQ/500VDC.
- Impermeability: After the entire cable (including connectors) is immersed in water for 12 hours, the insulation resistance shall not be less than -100 M/500VDC.

MI heating cable is a kind of cable that uses nickel-chromium alloy as the conductor, magnesium oxide mineral insulation material as the insulator, and metal material stainless steel or alloy material as the sheath. When necessary, a plastic outer sheath or a layer of plastic outer sheath can be extruded outside the metal sheath. Low-smoke no chimney outer sheath.

Stainless steel sheathed mineral insulated heating cable

The stainless steel sheathed mineral insulated heating cable can meet the needs of high temperature conditions and high heating power (up to 250Wm). The maximum temperature of this series of heating cables can reach 650°C; the mineral insulated cable has excellent mechanical strength and corrosion resistance.

825 alloy sheathed mineral insulated heating cable

825 alloy sheathed mineral insulated [heating cables](#) can meet the needs of high temperature conditions and high heating power (up to 250/m). The maximum temperature of this series of heating cables can withstand up to 800 °C; the range of conductor resistance values is from mineral insulated cables with excellent Mechanical strength, high temperature resistance and corrosion resistance, suitable for various explosion-proof occasions and special areas.